



TECHNICAL MANUAL

CLAY ROOFING TILES

Unicoppo Clay Roof Tiles



ITALCOTTO
DESIGN CENTRE

Unicoppo Clay Roof Tiles

A combination of the traditional Coppo and Portuguese Tile, the “S” profile Unicoppo is a single pressed tile unearthing the true spirit of Tuscany. Generally easier to lay than the Coppo but still realising the defined curvature that European roofs are renowned for.

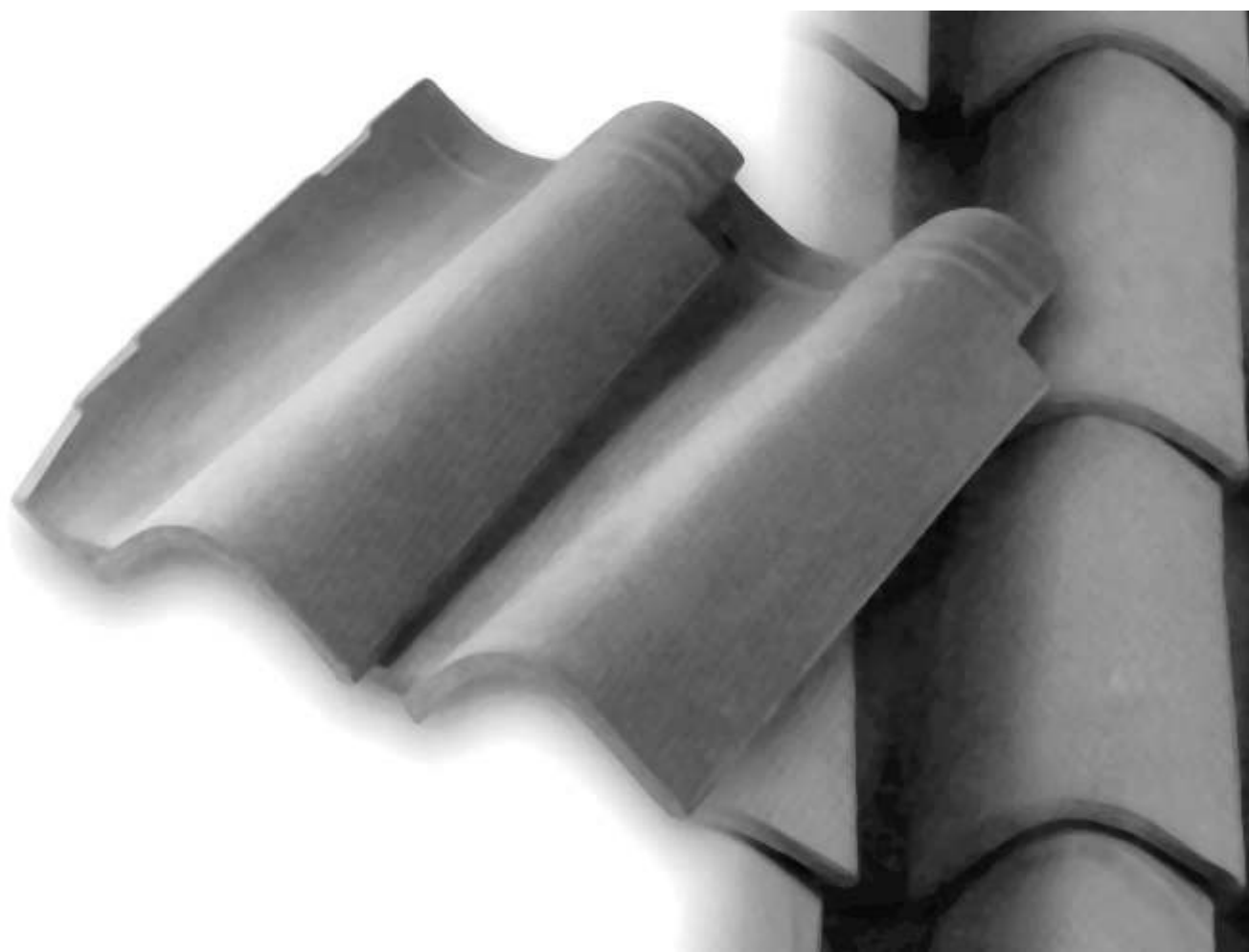

ITALCOTTO
DESIGN CENTRE

Unicoppo Clay Roof Tiles

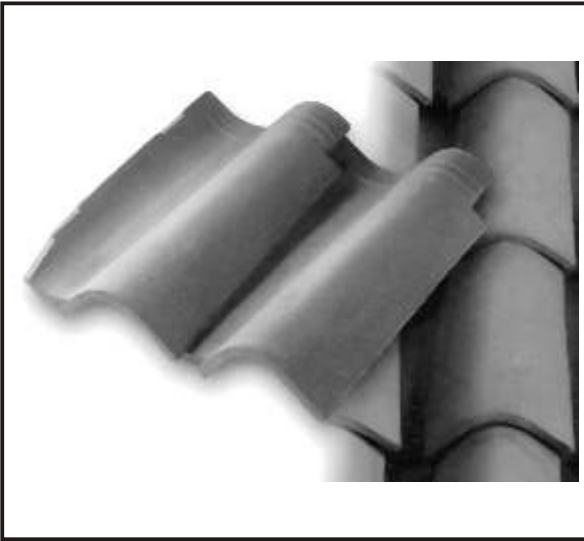

INSTALLATION

The following installation instructions are the recommended minimum requirements for the proper installation of Cunial Unicoppo Clay Tiles. The clay roof tile manufacturer is not familiar with all the building codes or regional weather conditions and does not control the installation of the tiles. The architect, or installer should ensure that Clay Roof Tiles are installed in accordance with the applicable local building codes and good roofing practice. Italcotto Ceramics does not and will not warranty any method of installation of these tiles.

UNDERLAYMENT:

Recommended underlayments installed over the sheathing are dependent on roof pitch and local weather conditions. On roofs below 17 degrees, tiles should be considered as a decorative finish only and laid over an impervious built-up membrane. On pitched roofs of 17 degrees or greater, cover entire roof area with plastic underlaying.

Underlayment should be laid parallel to the eaves with minimum 100mm horizontal lap and 150mm vertical lap with a minimum 300mm upstand at all abutments. An additional layer of underlayment should be secured with large flat-headed non-corrosive roofing nails at 150mm centres.

FASTENERS:

At the eave a 38 x 50 softwood cant strip should be installed to the fascia board. This will support

the toe of the eave course of the tiles and set them at the correct angle.

The eave course of tiles should be set to overhang the fascia board by at least 50mm. Tiles are laid from bottom right to top left of the roof. Each tile should be secured with a single non-corrosive 72mm roof nail. Please note that final drilling of the holes is required prior to nailing.

All pitched roofs are affected by wind pressure and this varies dependent upon the pitch of the roof, the exposure of the building and the height of the roof from the ground. Please check with your local building code, but as a general rule:

1) All field tiles in the eave course of any roof should be clipped with an eave tile clip, positioned in the left hand channel, secured to the batten with non-corrosive nails. (An Elite galvanised clip is suggested).

The nibs of the tiles should sit directly behind the batten and rest against the top of the tile batten. When the tiles are laid together, the overlap should cover the underlap completely. They must not override the underlap at the head of the tile.

2) On roofs in exposed or coastal locations, subject to high winds, each tile in every third course should be clipped.

3) On any roof 3 stories or higher, all tiles should be individually clipped. As the distributor

we cannot insist that this procedure be adopted, but we do consider it to be good roofing practice.

RIDGE:

A wood nailer should be secured to the apex of the ridge to support the ridge tiles. It should be set at a height to allow the ridge tiles to rest on the top course of field tiles. The top course of field tiles should be finished close to the ridge board.

The interlocking ridge tiles should be secured to the ridge nailer with a non-corrosive nail. Where they interlock they should be bedded in mortar. Where it is necessary to finish the top course of field tiles with a cut, the installer should cut the tile, on site, and drill the head of the tile and nail in the normal way.

The resulting gap between the ridge tile and field tile can be filled with colour matched mortar.

Ensure that no bedding is visible on the exposed surface of the tiles.

HIPS:

A wood nailer should be secured to the apex of the hip. It should be set at a height to allow the hip tile to be supported for nailing and rest on the adjacent cut field tiles.

The field tiles either side of the hip should be cut close to the wood nailer and all cut tiles firmly secured. Small cut tile pieces can be secured using a silicon adhesive.

Ensure that the first hip tile is set at the same angle as the others. Secure to the nailer with a single non-corrosive nail and where the hip tiles overlap they should be secured with mortar. The hip tile should be bedded in colour matched mortar and either flush pointed or back bedded. Ensure that no mortar marks the face of the tiles.

VALLEYS:

Open valleys should be formed using a long-life lead flashing. The valley metal should be a minimum of 500mm wide for short valleys and 600mm wide for longer valleys and in length, no greater than 2.5m. Sheets should be lapped by 100mm and not soldered.

On a steep valley with unequal pitches you might consider a 25mm crease on the centre line to

reduce the force of the water and direct the flow. A wide open valley is strongly advised in locations that will experience high snow loading or where heavy roof debris accumulation is likely. The edge of the valley metal should be turned over 120mm and secured to the deck with cleats. The tile should be cut to form an open valley 150mm wide, The cut tiles should be secured without puncturing the valley metal. Open valleys should be bedded in mortar and flush pointed. You should ensure that the valley evenly discharges over the fascia board into the gutter.

ABUTMENTS:

Side Abutments:

Where field tiles finish against a vertical abutment the underlayment should be turned up the wall at least 150mm and over the deck an even amount. The edges of the deck flashing should be turned up 25mm to form a secret gutter, directing water down the roof and discharging into the gutter. The flashing should be firmly secured to the wall. You might consider setting the flashing in a bed of flexible roof cement, to give additional protection, at this vulnerable junction. The tiles can then be laid close to the wall. On brick abutments a cover flashing let into a mortar joint can be installed.

Head Abutments:

The underlayment will be returned up the wall at least 150mm and secured. The top course of field tiles will then be laid. Where it is necessary to finish the top course with a cut tile, the installer should cut the tile on site, and drill each head, then secure to the deck in the normal way. The resulting gap under the tiles can either be filled with colour match mortar or with a purpose-made rubber top filler. Ensure that no bedding is visible on the exposed surface of the tiles. A metal flashing should be formed to the correct angle, it will abut the wall by at least 150mm and cover the head of the tiles by 150mm. With a brick abutment, the flashing can be returned into the mortar joint and a cover flashing installed. When flashing behind a chimney it is always advisable to form a saddle to divert the water around the chimney. The saddle should be weathered in suitably compatible flashing material.

PACKING OF MATERIAL

Pallets: 220 pieces per pallet.

SPECIAL PIECES:

- a) Hip and ridge tiles: 2,5 pieces per linear metre
- b) Hip end caps
- c) Air vent tiles

Unicoppo Clay Roof Tiles

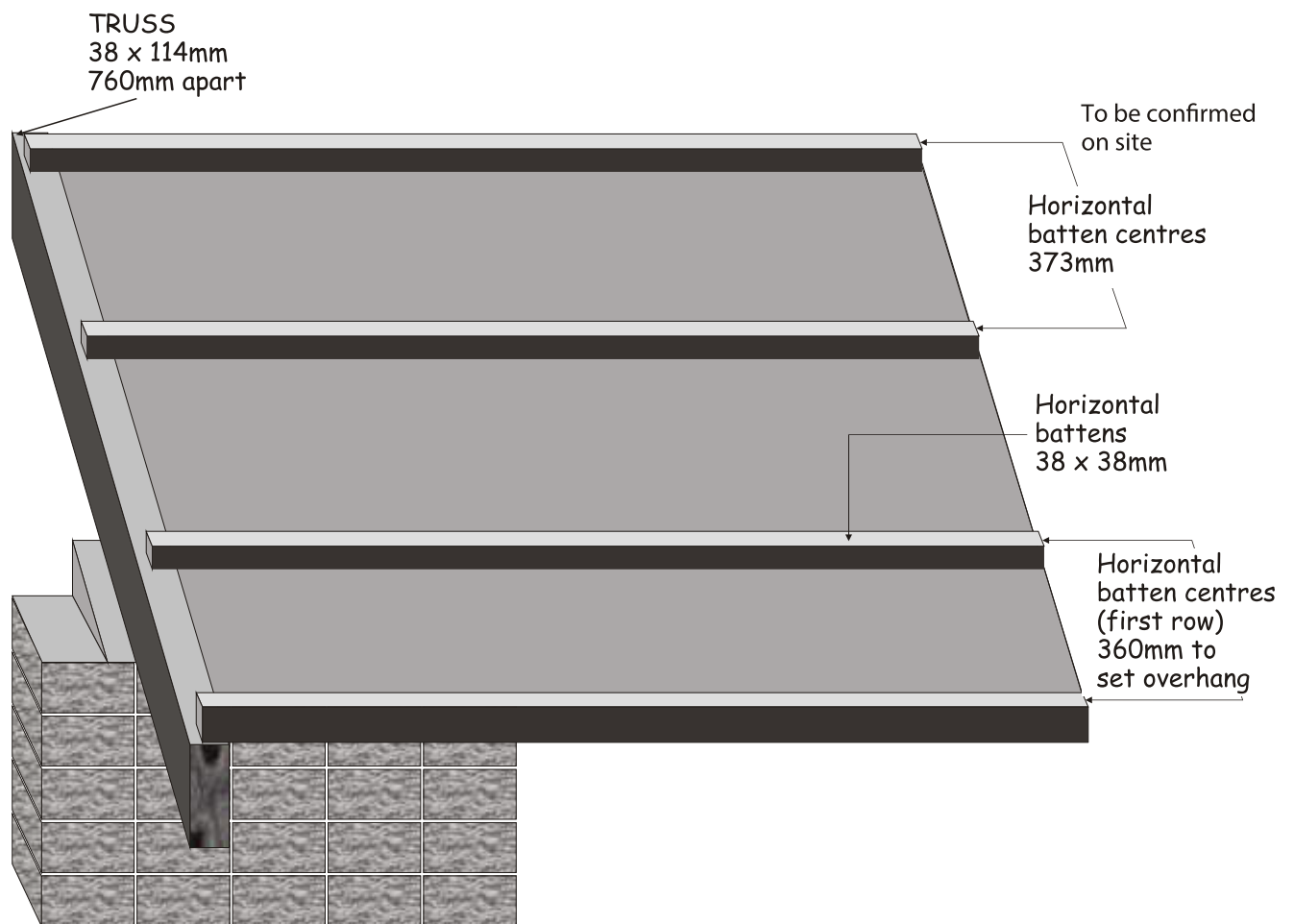

SUGGESTED BATTEN LAYOUT

Roof Tile Specification

Unicoppo Clay Roof Tiles

- 12.5 pieces per sqm coverage
- 4.2kg per piece
- 52.5 kg per sqm
- Recommended Horizontal Battern Spacing: 370 - 380mm
- Length: 490mm
- Width: 280mm

Unicoppo Clay Roof Tiles

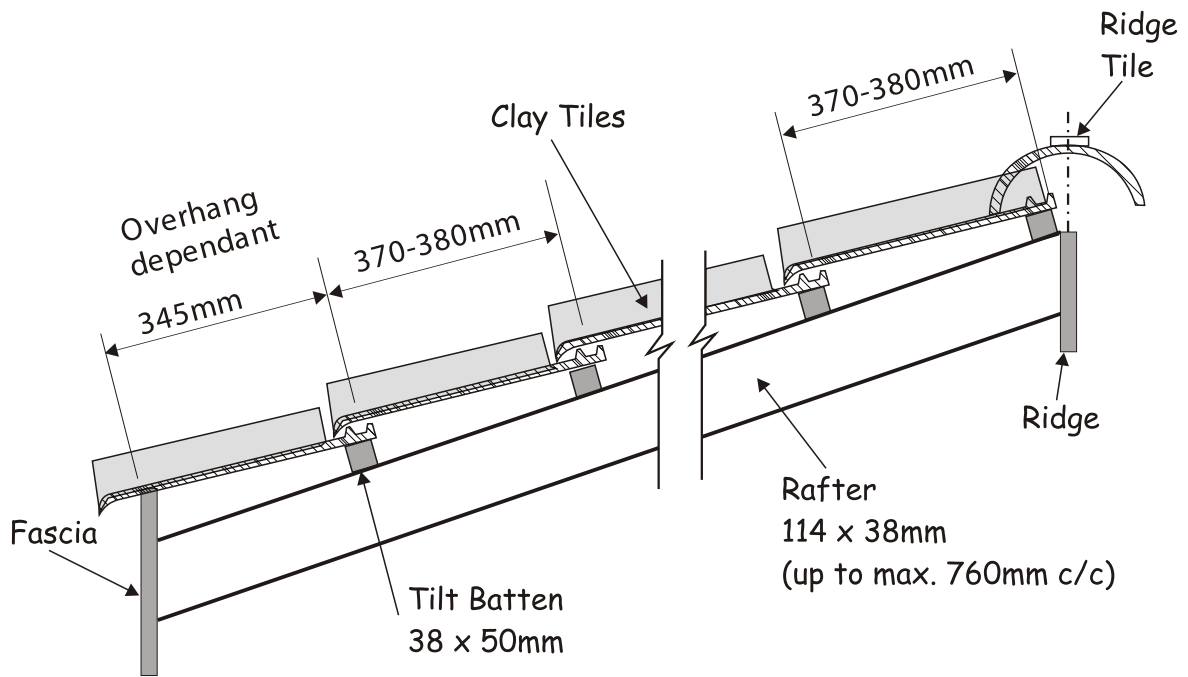

SECTION - ALONG RAFTER